

COMPACT TS

Labelling system for application onto cylindrical products.

Standard features

Max. speed	3600 p/hour
Labelling module	LABELX JR 140-250
Electronic control	in separate box ER
Max. label width	140-250 mm

Conveying module with flat belt | COMPACT main frame in painted steel | Horizontal and vertical microregulation unit

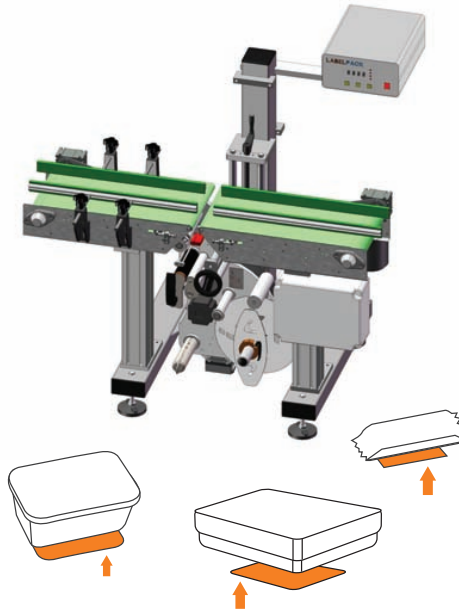

COMPACT BS

Labelling system for bottom side application onto flat products.

Standard features

Max. speed	3600 p/hour
Labelling module	LABELX JR 140-250
Electronic control	in separate box ER
Max. label width	140-250 mm

Conveying module with double flat belt | COMPACT main frame in painted steel | Horizontal and vertical microregulation unit

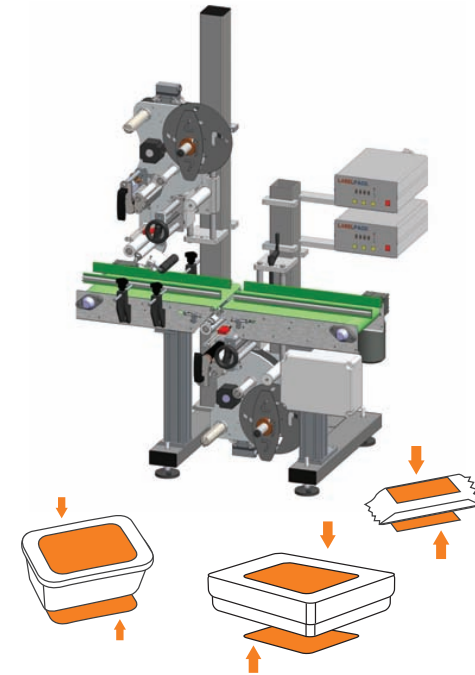

COMPACT TB

Labelling system for top and bottom side application onto flat products.

Standard features

Max. speed	3600 p/hour
Labelling module	Two (2) LABELX JR 140 -250
Electronic control	in separate box ER
Max. label width	140-250 mm

Conveying module with double flat belt | COMPACT main frame in painted steel | Double horizontal and vertical micro regulation unit

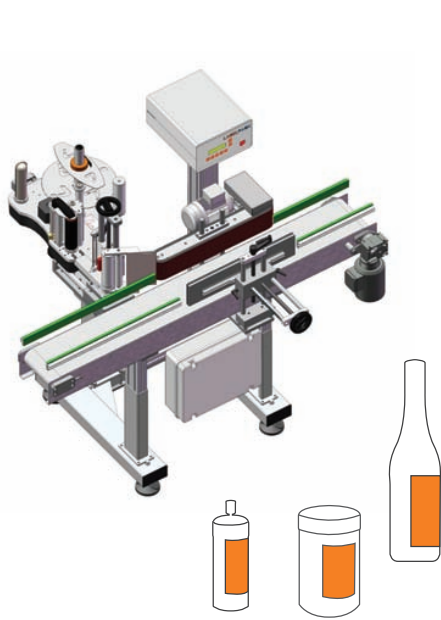

COMPACT WA

Labelling system for application onto cylindrical products.

Standard features

Max. speed	3600 p/hour
Labelling module	LABELX JR 140-250
Electronic control	in separate box ER
Max. label width	140-250 mm

Conveying module with flat belt | Wrap around device with AC motor plus inverter | COMPACT main frame in painted steel | Horizontal and vertical micro regulation unit

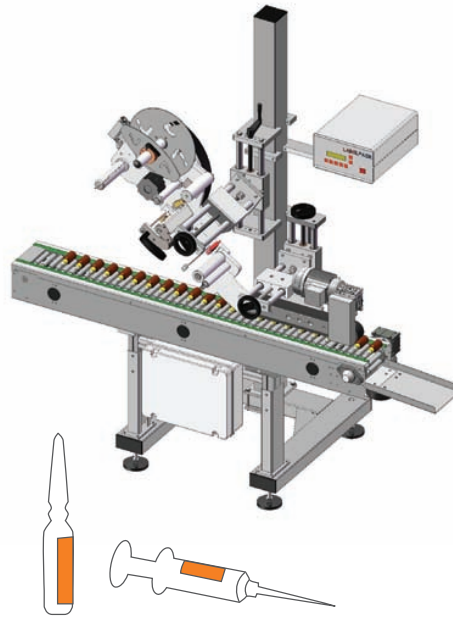

COMPACT WR

Labelling system for application onto vials and cylindrical products with small diameter.

Standard features

Max. speed	3600 p/hour
Labelling module	LABELX JR 140-250
Electronic control	in separate box ER
Max. label width	140-250 mm

Conveying module with parallel chains and free rollers | Wrap around device with AC motor plus inverter | COMPACT main frame in painted steel | Horizontal and vertical micro regulation unit

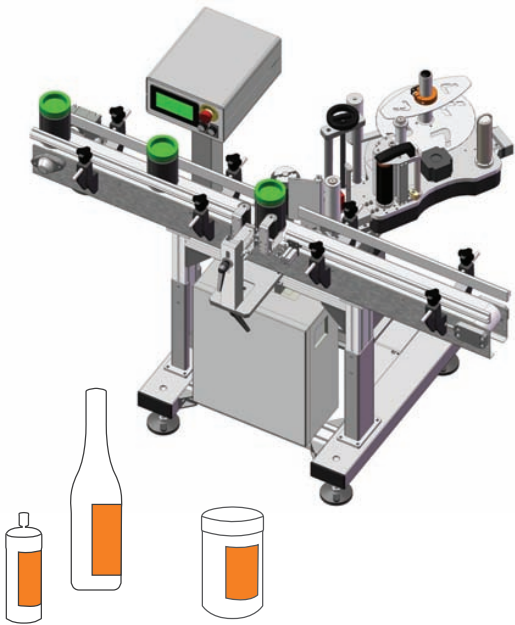

COMPACT WX

Labelling system for application onto cylindrical products in stop position.

Standard features

Max. speed	3600 p/hour
Labelling module	LABELX JR 140-250
Electronic control	in separate box ER
Max. label width	140-250 mm

Conveying module with flat belt | Wrap around device on standing position with 3 pneumatic roller device | COMPACT main frame in painted steel | Horizontal and vertical micro regulation unit